

Onland

SWIFT

ASSEMBLY INSTRUCTIONS
OPERATING INSTRUCTIONS
WARRANTY



MADE IN CHINA and IMPORTED BY ONLAND AUSTRALIA

Warehouse & Head office, 7-9 Allen Street, Loganholme, Qld4129, PH: 07 3806 5766

Sales Enquiries: sales@onland.com.au













Service Enquiries: service@onland.com.au

ASSEMBLY INSTRUCTIONS

SWIFT

Remove all items from the carton. Verify all pieces before assembly.

PARTS LIST

Key	Description	Part	Qty.	Spare
A	Caster		5 pcs	
B	Star Base		1 pc	
C	Gas Lifter		1 pc	
D	Mechanism		1 pc	
E	Armrest		2 pc	
F	Back Cushion		1 pc	
G	Seat Cushion		1 pc	
H	Back Armrest screws (M6*25mm)		4 pcs	1
I	Seat Armrest screws (M6*35mm)		4 pcs	1
J	Mechanism screws (M6*20mm)		4 pcs	1
K	Washers		4 pcs	
L	Armrest cover		4 pcs	
	Allen Wrench(6mm)		1 pc	

PREVENTIVE MAINTENANCE AND WARNING!

- USE THIS PRODUCT ONLY FOR SEATING ONE PERSON AT A TIME.
- DO NOT USE THIS CHAIR AS A STEP STOOL/ LADDER.
- DO NOT SIT ON ANY PART OF THE CHAIR EXCEPT THE SEAT.
- DO NOT USE CHAIR ON UNEVEN FLOOR SURFACES.
- DO NOT USE CHAIR UNLESS ALL BOLTS, SCREWS AND KNOBS ARE TIGHTENED EVERY SIX MONTHS, PLEASE MAKE SURE ALL BOLTS, SCREWS AND KNOBS ARE FULLY TIGHTENED TO ENSURE STABILITY.

- IF ANY PARTS ARE MISSING, BROKEN, DAMAGED OR WORN, STOP USE OF THE PRODUCT UNTIL REPAIRS ARE MADE USING FACTORY AUTHORIZED PARTS.
- DISPOSE OF PACKAGING PROPERLY. PLASTIC BAG IS NOT A TOY. DO NOT USE PLASTIC BAG AS HEAD COVERING .IT MAY CAUSE SUFFOCATION.
- FAILURE TO FOLLOW THESE WARNINGS COULD RESULT IN SERIOUS INJURY.
- NOTE: SOME SCREWS MAY BE PREASSEMBLED. IF PREASSEMBLED, IGNORE ASSEMBLY INSTRUCTIONS.

ASSEMBLY INSTRUCTIONS

SWIFT

Remove all items from the carton. Verify all pieces before assembly.

STEP 1

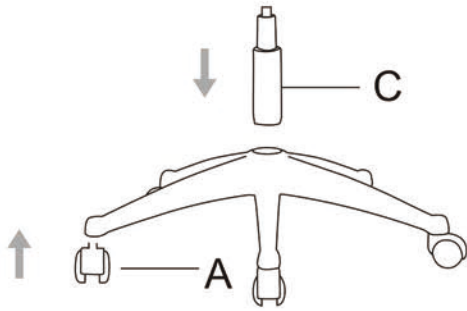

Press the Casters (A) into the holes at the end of each leg of Base (B). Insert the bottom end of the gas lifter (C), into the center hole of the base (B). Slide the gas lifter cover (M) onto the gas lifter (C)

STEP 2

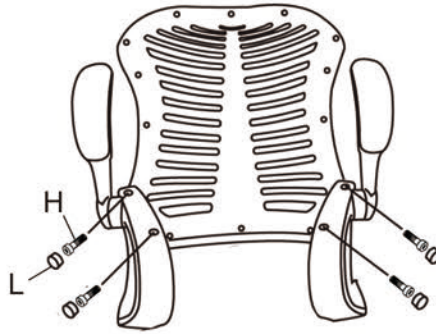

Using Back armrest screws (H) to fix the armrest (E) on the back cushion (F). Tighten the screws with the enclosed Allen Wrench (N). Put the armrest cover (L) on the armrest holes.

STEP 3

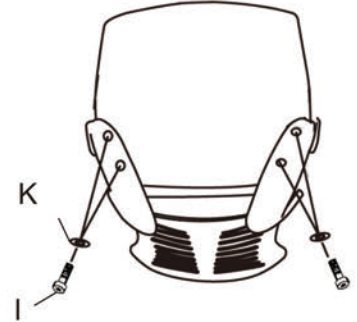

Using Seat armrest screws (I) and washers (K) to fix the armrest (E) on the seat cushion (G). Tighten the screws with the enclosed Allen Wrench (N).

STEP 4

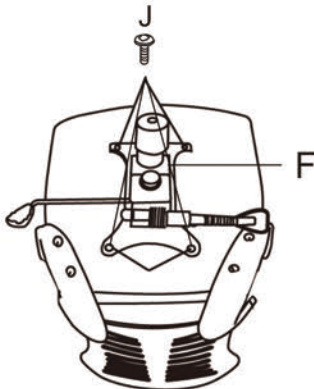

Using mechanism screws (J) to fix the mechanism (D) on the seat cushion (G). Tighten the screws with the enclosed Allen Wrench (N).

STEP 5

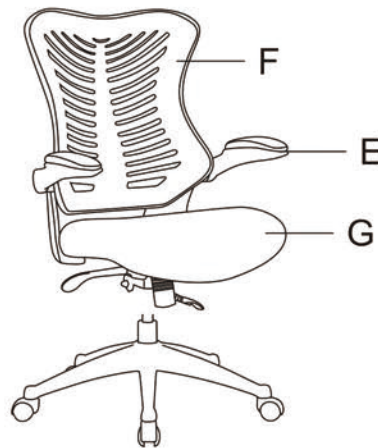

Now put the assembled back, seat and mechanism on to the assembled gas lifter. Push down firmly until the connection is ensure

STEP 6



Before using your chair, ensure all the screws are tightened fully for safety. You can now enjoy the comfort of your new chair. Please keep the Allen Wrench and check all screws every six months to ensure they remain tightly fastened.

PREVENTIVE MAINTENANCE AND WARNING!

- USE THIS PRODUCT ONLY FOR SEATING ONE PERSON AT A TIME.
- DO NOT USE THIS CHAIR AS A STEP STOOL/LADDER.
- DO NOT SIT ON ANY PART OF THE CHAIR EXCEPT THE SEAT.
- DO NOT USE CHAIR ON UNEVEN FLOOR SURFACES.
- DO NOT USE CHAIR UNLESS ALL BOLTS, SCREWS AND KNOBS ARE TIGHTENED EVERY SIX MONTHS, PLEASE MAKE SURE ALL BOLTS, SCREWS AND KNOBS ARE FULLY TIGHTENED TO ENSURE STABILITY.

- IF ANY PARTS ARE MISSING, BROKEN, DAMAGED OR WORN, STOP USE OF THE PRODUCT UNTIL REPAIRS ARE MADE USING FACTORY AUTHORIZED PARTS.
- DISPOSE OF PACKAGING PROPERLY. PLASTIC BAG IS NOT A TOY. DO NOT USE PLASTIC BAG AS HEAD COVERING. IT MAY CAUSE SUFFOCATION.
- FAILURE TO FOLLOW THESE WARNINGS COULD RESULT IN SERIOUS INJURY.
- NOTE: SOME SCREWS MAY BE PREASSEMBLED. IF PREASSEMBLED, IGNORE ASSEMBLY INSTRUCTIONS.

OPERATING INSTRUCTIONS SWIFT

A SEAT HEIGHT ADJUSTMENT

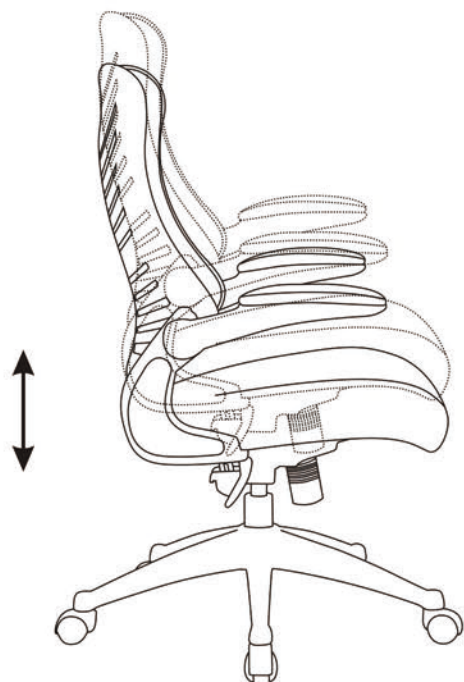

B 360° SWIVEL

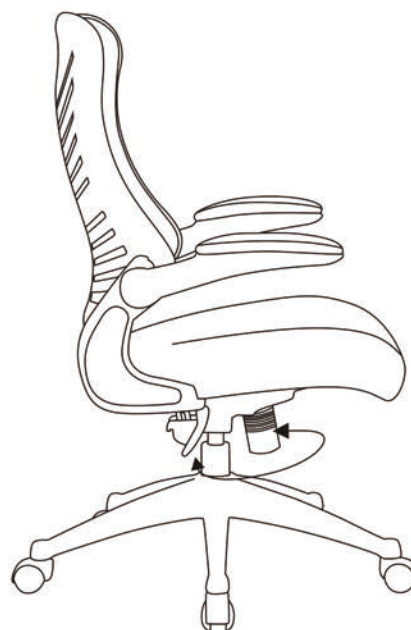

A SEAT HEIGHT ADJUSTMENT

While seated, pull the level on the right side of the seat up and hold it while raising or lowering the seat to change the seat height. While the level is released, the seat height is locked. The seat height adjustment range is approximately 2.36"

B 360° SWIVEL

Your chair can rotate around 360°.



CARE AND CLEANING

To maintain the appearance of this product wipe surfaces with a clean, non-abrasive cloth dampened with a mild detergent solution.

Treat spills and stains as soon as possible. Spot clean as above. Persistent stains may require treatment by a professional cleaner.

Do not remove any parts for separate cleaning.

Do not shampoo clean.

Do not clean with hot water extraction machine.

Do not clean with on-site dry-cleaning machine.

Protect from direct sunlight, heat and weather.

Allow to dry thoroughly before reuse.

ADDITIONAL CARE:

FOR FABRIC – A soft bristle brush may be used to remove ingrained soil. Fabric may be cleaned with dry powder cleaners.

FOR BONDED LEATHER/LEATHER – A soft bristle brush may be used to remove ingrained soil. Use only leather care products suitable for top coated leather and strictly in accordance with the manufacturer's instructions.

FOR VINYL/PU – Use only vinyl care products suitable for upholstery vinyl and strictly in accordance with the manufacturer's instructions.

WARRANTY

Onland Office chairs are warranted for faulty workmanship and /or materials from the date of purchase.

The following are excluded from the above:

(a) Normal wear and tear and normal fade.

(b) Scratching and abrasion.

(c) Neglect, misuse or accident.

Given the above exclusions, Onland Australia will repair or replace parts which fail within the above periods from the date of purchase. Onland Australia reserves the right to substitute similar merchandise should the model or color in question no longer be available.

Our goods come with guarantees that cannot be excluded under the Australian Consumer Law. You are entitled to a replacement or refund for a major failure and for compensation for any other reasonably foreseeable loss or damage. You are also entitled to have the goods repaired, replaced or partly replaced if the goods failed to be of acceptable quality and the failure does not amount to a major failure.

Please contact your retailer should you wish to make a warranty claim.